



Model T-360

Model T-360 Pyramid-Shape Pouch Forming and Packaging Machine

T-360

Eye-catching package by unique and attractive triangular-pyramid pouch.

- Three-dimensional pyramid-shaped pouch created by reciprocal sealing operations of 2 sets of horizontal sealing bars.
- Reliable print-registration pitch control in film feeding by servo-controlled vertical sealing bar. Easy change of pouch length by touch-panel operation.
- Easy conversion to standard pillow sealing pouch simply by changing horizontal sealer position.
- Standardly equipped with volumetric measuring device (rotary disk). Can also interlink with weigher and auger filler.



The photo shows the T-360 model.

The T-360 offers dependable packaging speed and excellent machine durability, thanks to the simple structure with a vertical sealing bar and two sets of horizontal sealing bars.

■ Illustration of pyramid-shape pouch

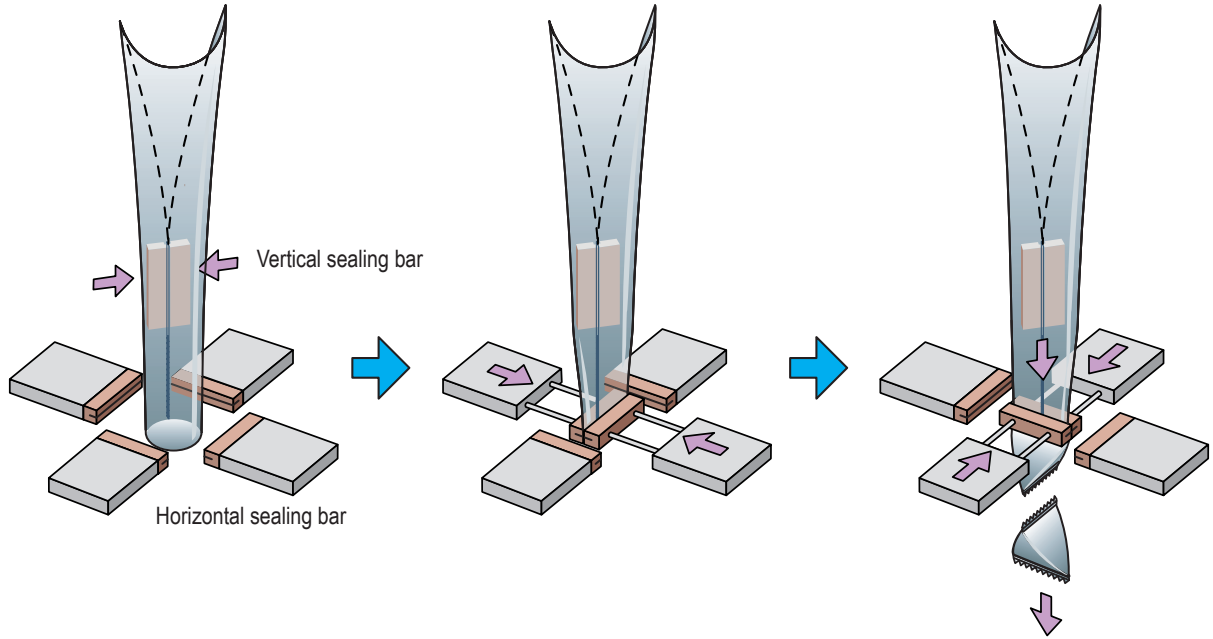

Application examples

- Peanuts, Raisins, Chocolates, Candies, Beans, Dried fruits, etc.

Standard equipment

- Print registration system
- Heater disconnection detector
- Safety cover with auto-stop
- Film tensioner
- Film end detector

Optional equipment

- Code printer (Hot printer)
- Nitrogen gas filling unit
- Serrated cutter
- Horizontal seal biting detector
- Blending disk unit
- Hopper level sensor
- Inclined counting disk unit
- Defect rejecting unit
- Discharge conveyor

■ Blending disk unit (option)



■ Main specification

Packaging speed	Max.80 pouches/min. (Varies depending on products and packaging materials.)
Packaging materials	OPP/CPP, PET/CPP, Aluminum/PE, Other laminated film.
Pouch size range	Width: 30 to 75mm Length: 40 to 110mm
Machine dimensions	Approx. 950(W) 1,000(D) 1,850(H)mm
Machine weight	Approx. 350kg
Power consumption	3 Phase, 200VAC, 1.5Kw
Air consumption	Approx. 0.5MPa · 240NL/min.(ANR)

■ Dimensional diagram

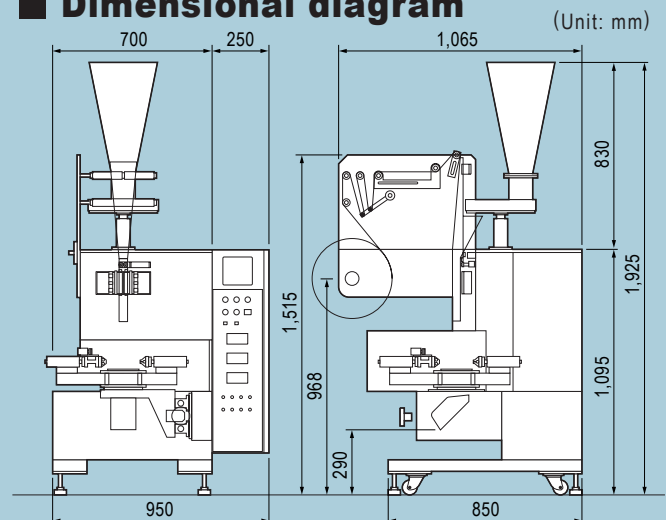

*Specifications are subject to change without notice.



TOPACK CO.,LTD.

15-10, Kamihigashi 6-chome Hirano-ku, Osaka 547-0002, Japan
Phone : 81-6-6792-7341 Fax : 81-6-6794-3074
URL : <http://www.topack.co.jp/>